

# Instruction manual

## POWERVOICE PV-5D.2-2U

### AUTOMATIC MIXING AMPLIFIER WITH 100V OUTPUT

Internal digital  
power amplifier  
(class D)

NOISE GATE

21-Band EQ

Parametric EQ

ENGLISH

PV-5D.2-2U – AUTOMATIC MIXING AMPLIFIER WITH 100V OUTPUT



Phoenix Professional Audio GmbH  
Gewerbepark Markfeld 5  
D-83043 Bad Aibling  
Tel.: +49(0)8061-495603-0  
Fax: +49(0)8061-495603-1  
[www.phoenix-pa.com](http://www.phoenix-pa.com)  
[www.phoenix-pa.com/shop](http://www.phoenix-pa.com/shop)

© Copyright 2019 Phoenix Professional Audio GmbH  
[www.phoenix-pa.com](http://www.phoenix-pa.com) / [www.phoenix-pa.com/shop](http://www.phoenix-pa.com/shop)  
Phoenix logo is registered with the DE Patent and Trademark Office (TM)  
All trademarks are the property of their respective owners



V-1.0

DOC-260919

## IMPORTANT SAFETY INSTRUCTIONS & SYMBOL DECLARATION

1. Read this manual carefully.
2. Keep this manual in a safe place.
3. Observe all warnings.
4. Follow all instructions.
5. **WARNING:** To reduce the risk of fire or electric shock, do not expose this equipment to rain or moisture.  
Do not use this device near water.
6. Clean only with a dry cloth.
7. Do not cover any ventilation openings.
8. Do not install near heat sources such as radiators, air vents, stoves or other equipment (including amplifiers) that radiate heat.
9. Do not override the safety function of the polarity reversal protection or earthing contact plug. A connector with polarity reversal protection has two pins, one wider than the other (USA / Canada only). A safety plug has two pins and a ground terminal. If the supplied plug does not fit into your outlet, it will be outdated and must be replaced by an electrician.
10. Route the power cord so that nobody can step on it or get caught. This particularly applies to plugs, sockets and the point where the cable exits the device.
11. Use only Phoenix Professional Audio GmbH products and specified accessories.
12. Have maintenance performed by qualified service personnel only. The device must always be serviced if it has been damaged in any way, for example, if the power cord or plug is damaged, liquids have been spilled on the product, or objects have fallen into the product, the product has been exposed to rain or moisture, is not working normally, or has been dropped.

## EXPLANATION OF GRAPHIC SYMBOLS



**AVIS: RISQUE DE CHOC ELECTRIQUE !  
NE PAS OUVRIR !**



The exclamation mark in a triangle is intended to alert the user to the presence of important operating and maintenance instructions in this manual.



The symbol consisting of a lightning bolt with an arrowhead in a triangle is intended to alert the user to the presence of non-isolated, dangerous voltages within the housing that may be strong enough to give off an electric shock.



**CAUTION: TO REDUCE THE RISK OF ELECTRIC SHOCK, DO NOT REMOVE THE COVER. USE QUALIFIED PERSONNEL FOR ALL MAINTENANCE WORK.**

## GENERAL INFORMATION

The PV-5D.2-2U is a top-of-the-range automatic mixing amplifier with a transmission quality that far exceeds the requirements of **DIN 45500**.

The automatic mixer amplifier is equipped with **digital power amplifier (Class-D)** and 200 watts of power (100 V).

All outputs are **electronically balanced with equipotential bonding**.

All microphone / line inputs 1 to 4 are equipped with separate treble and bass controls, switchable phantom power, HPF filter and sensitivity control (**GAIN**) (on the back).

Automatic mixers of the POWERVOICE series are equipped with **automatic NOISE GATE system** for the microphone inputs (1-4). The **21-band graphic EQ**, together with the **parametric EQ** and Feedback-Limiter (**shifter**), provides more accurate spatial equalization and excellent spatial acoustics. Furthermore, the automatic mixers have an additional speaker line (100V output) with separate volume control and **SOFT START** for reducing the noise and for better speaker protection.

POWERVOICE „D“ series now with **digital power amp technology**:

Phoenix Professional Audio's POWERVOICE automatic mixers have been redesigned and improved, especially in their electronics: A new digital amplifier (Class-D) has been installed in the automatic mixers of the new „D“ series - the state of the art. The fans in all new amplifier models are temperature controlled and, in contrast to the fans of the previous versions, are very quiet. The new „D“ series is also very **energy efficient**.

The devices are developed as table version. 19" mounting (2U) available on request. Further details can be found in the technical data.

For power boosting, power amplifiers of the series **WM-200DT**, **WM-400DT** and **WM-600DT** are available.

These devices comply with the Electromagnetic Compatibility Directive 89/336/EEC and the Low Voltage Directive 73/23/EEC.

## SAFETY INSTRUCTIONS

Before putting the automatic mixing amplifier PV-5D.2-2U into operation, we ask you to carefully read the safety instructions.

We ask you to perform the installation according to the following guidelines:



- 1 - Always place the amplifier on a flat and stable surface.
- 2 - Choose a dry environment and do not put liquids on the amplifier.
- 3 - Avoid the proximity of heat sources.
- 4 - Never open the case of the amplifier without disconnecting the power plug from the socket.
- 5 - Only connect the device to 230 VAC mains voltage.

## MAIN FEATURES

- Short circuit protection - Overheat protection - Open circuit protection - Overload protection
- LED - level display, PROTECT, OK
- 100V, 70V, 50V, 8 ohm and 4 ohm speaker outputs
- SOFT START to suppress switch-on noise
- Balanced Microphone / Line Inputs (DIP Switch)
- Electronically balanced LINE IN / LINE OUT inputs / outputs with equipotential bonding
- Phoenix connectors for speaker lines
- Separate volume control for all inputs with 2-fold EQ
- Recessed EQ controls on the front, Parametric & Graphic-EQ
- Feedback limiter (SHIFTER) with BYPASS switch
- Automatic NOISE GATE system control LED's
- 21 band graphic EQ
- Parametric EQ with 150Hz to 2kHz @ 0dB-20dB control
- Output REC
- Separate speaker line for e.g. controlling loudspeaker or sound reinforcement of the gallery
- Space-saving 2 U housing version

## BLOCK DIAGRAM

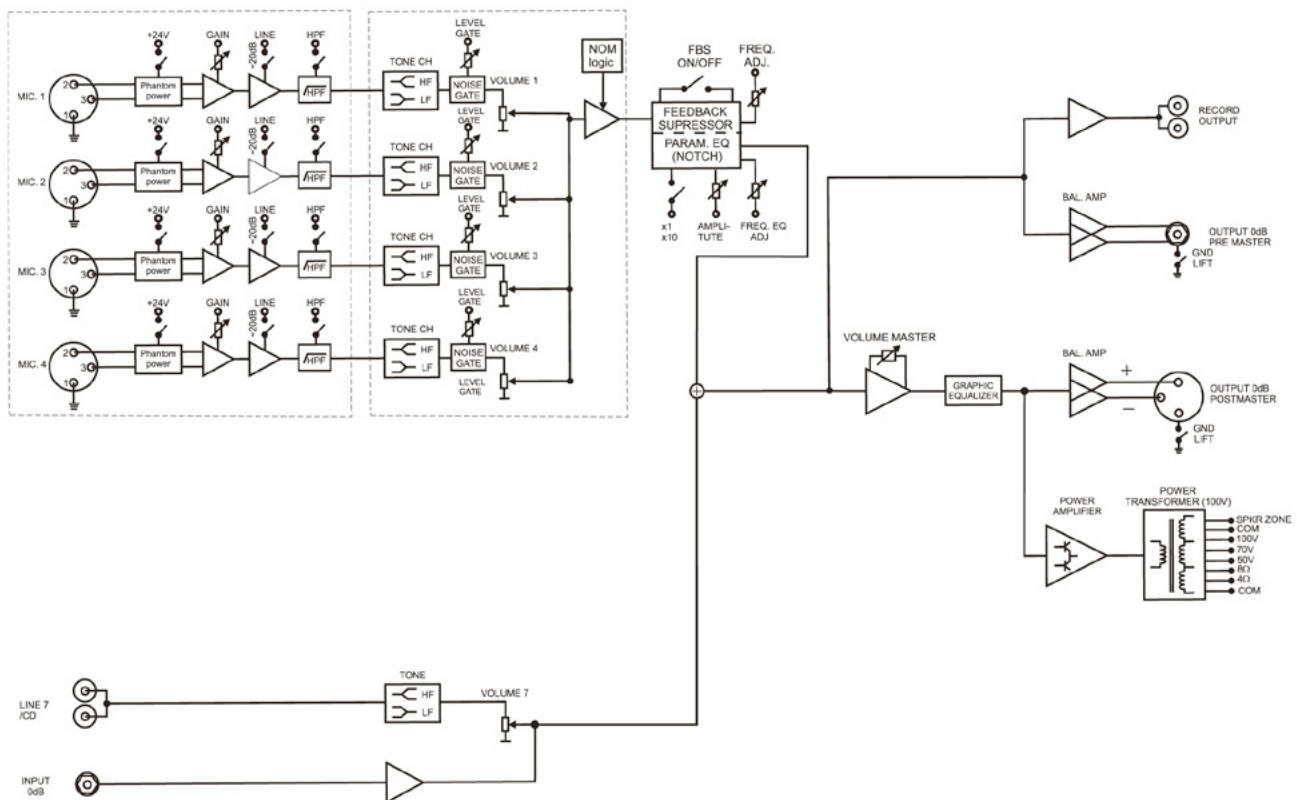

## TECHNICAL DRAWING (FRONT SIDE)

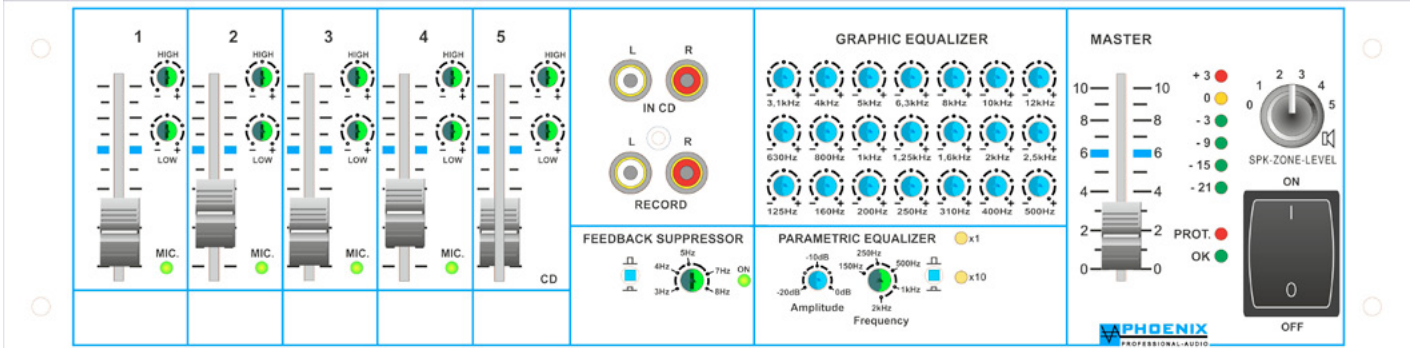

## TECHNICAL DRAWING (REAR SIDE)

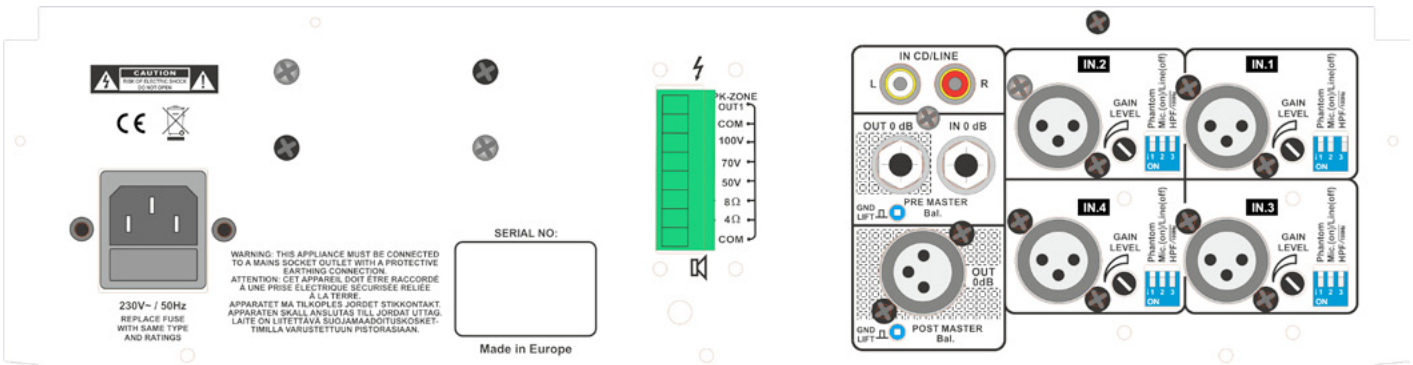

## FRONT SIDE

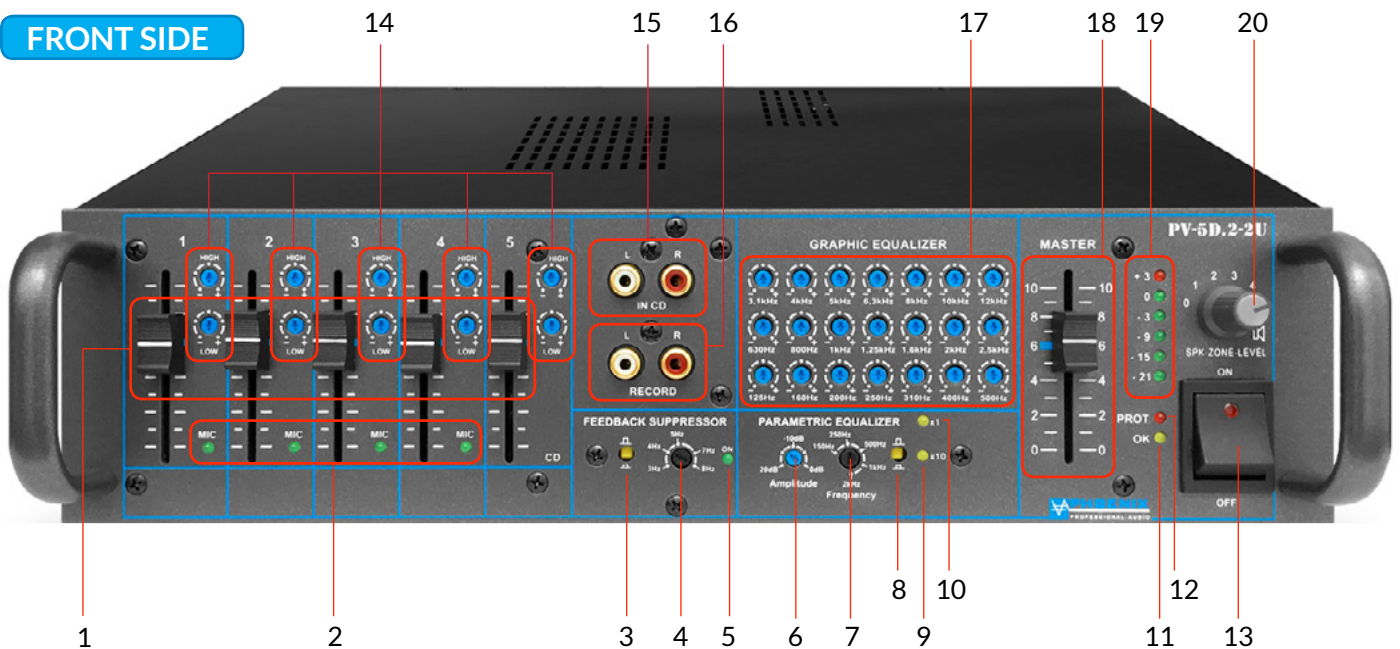

### 1. VOLUME CONTROL

This control (level slider) determines the volume of the MIC.-LINE inputs 1 to 4.

### 2. CONTROL LED's AUTOMATIC SYSTEM

Green LED indicators light when the automatic system allows input signal. If the input is not addressed, the control LED remains dark and the input „GATE“ remains closed.

### 3. BYPASS SHIFTER

With this switch, the feedback limiter can be switched to BYPASS, the control LED does not light up.

### 4. FREQUENCY SHIFT CONTROL

This control adjusts the desired frequency shift. The control range is between 3 Hz and max. 8 Hz up in the whole bandwidth from 20 Hz to 20 kHz.

Due to the frequency shift, the „whistling sound“ (feedback between microphone and loudspeakers) occurring in the signal can be additionally eliminated after the audio calibration of the system. After that, the quality losses of the audio signal remain barely perceptible.

### 5. LED CONTROL SHIFTER

Lights up when the feedback limiter is switched on.

### 6. AMPLITUDE CONTROL (PARAMETRIC EQ)

This control, also referred to as *frequency gain*, adjusts the amount of attenuation of the selected frequency.

### 7. FREQUENCY SELECTOR SWITCH (PARAMETRIC EQ)

This control adjusts the desired frequency for parametric EQ.

### 8. MULTIPLICATOR SWITCH (PARAMETRIC EQ)

Selector switch for multiplication of the set frequency by factor **x1** or factor **x10**.

## FRONT SIDE

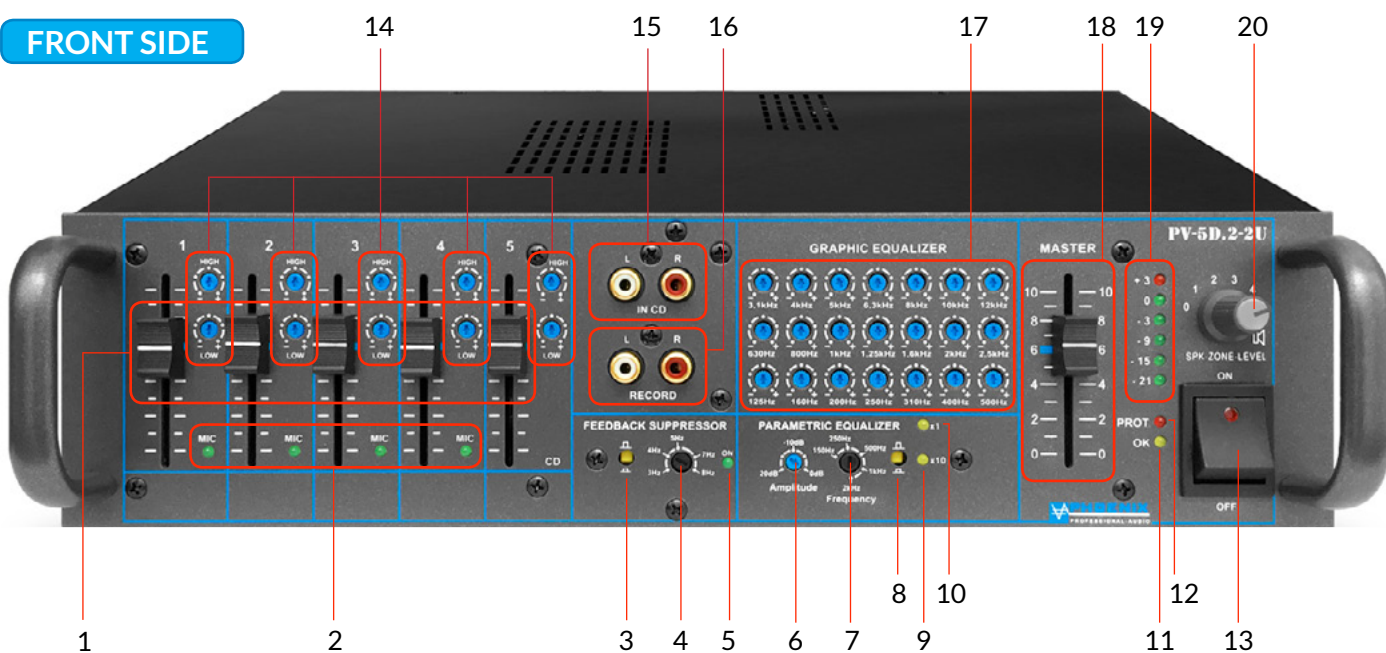

### 9. CONTROL LED OF MULTIPLICATOR SWITCHES (PARAMETRIC EQ)

LED lights up when multiplying the set frequency by factor x10.

### 10. CONTROL LED OF MULTIPLICATOR SWITCHES (PARAMETRIC EQ)

LED lights up when multiplying the set frequency by factor x1.

### 11. OPERATION DISPLAY

Lights up when the amplifier is switched on (POWER ON).

### 12. CONTROL LED's, LIMITER, SYSTEM OK



If the PROTECT indicator lights up without an input signal, system vibration or other interference may be present. Disconnect the load and reduce the gain to zero. If the LED remains lit, the amplifier may need to be serviced.

### 13. ON / OFF POWER WITH OPERATING DISPLAY

After pressing this switch, the device is ready for operation.

### 14. 2-BAND EQ

Separate LF and HF control of the individual MIC-LINE inputs.

### 15. LINE INPUT

Line input (0dB) with level shift control, LF and HF-EQ controls for e.g. CD player input, etc.

### 16. RECORD OUTPUT (recording output)

Unbalanced wired (0 dB), used to connect recording devices. The signal available for recording is the sum of the microphone and sound carrier inputs before MASTER volume control.

## FRONT SIDE

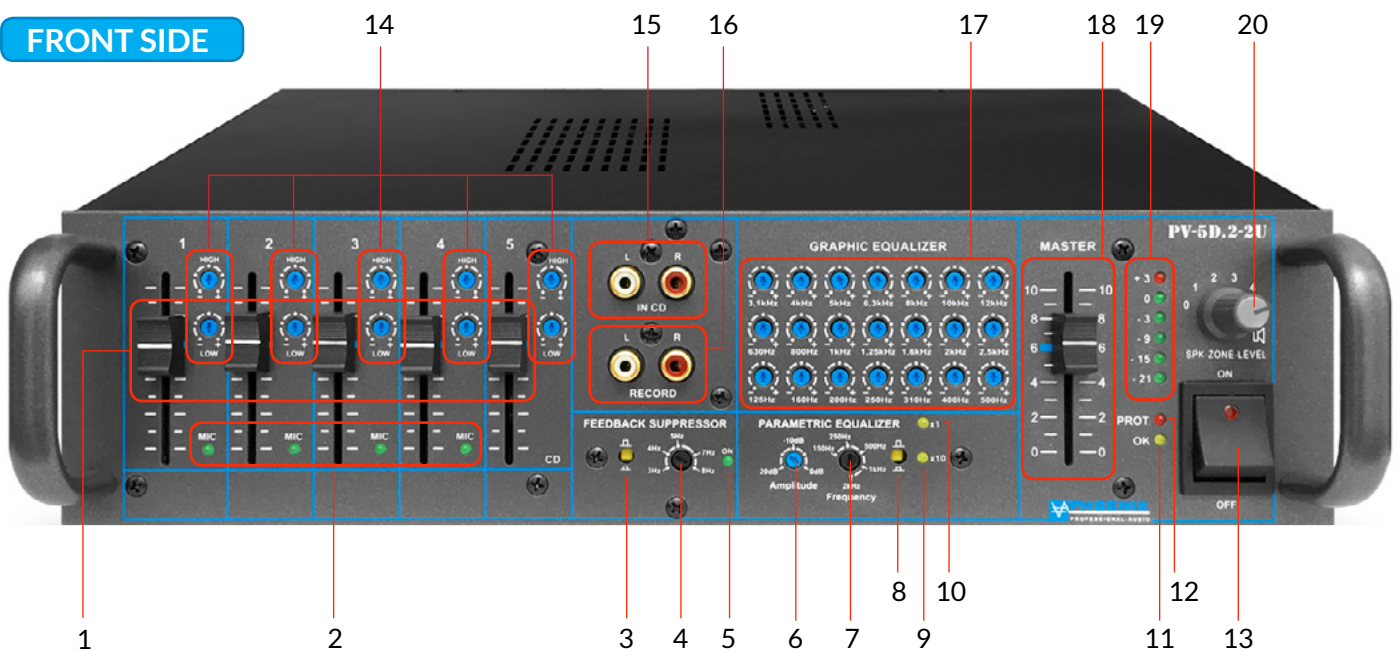

### 17. GRAPHIC EQUALIZER (EQ)

EQ with 21 band 1/3-octav equalizer with spindle trim potentiometers is used for room equalization, reduction of reverberation and improvement of the consonant intelligibility. The frequency of each filter can be raised or lowered in the range of 12 dB.

In the graphic EQ, the bandwidth of each band is selected so that the entire frequency range is covered with as few crosstalk (Q value) as possible.

### 18. MASTER SECTION

Use this control to raise or lower the overall volume.

### 19. LEVEL METER

The level meter lights up when the input signal exceeds -21 dB. If no indication is displayed, check the gain settings and increase the gain if necessary. Check the input terminals and the audio source for signals. If the PROT-LED is lit or the level meter is +3 dB, even though no signal is displayed, check the output wiring for short circuits.

### 20. SEPARATE LOUDSPEAKER LINE

Single speaker line for e.g. control speaker with 100V output and separate volume control (step switch).



Please note that the ZONE-1 output and the direct loudspeaker output are supplied from the same power output stage. The connected LOAD at the ZONE-1 and at the direct output should not exceed more than the max. power of the amplifier.



## REAR SIDE / CONNECTIONS

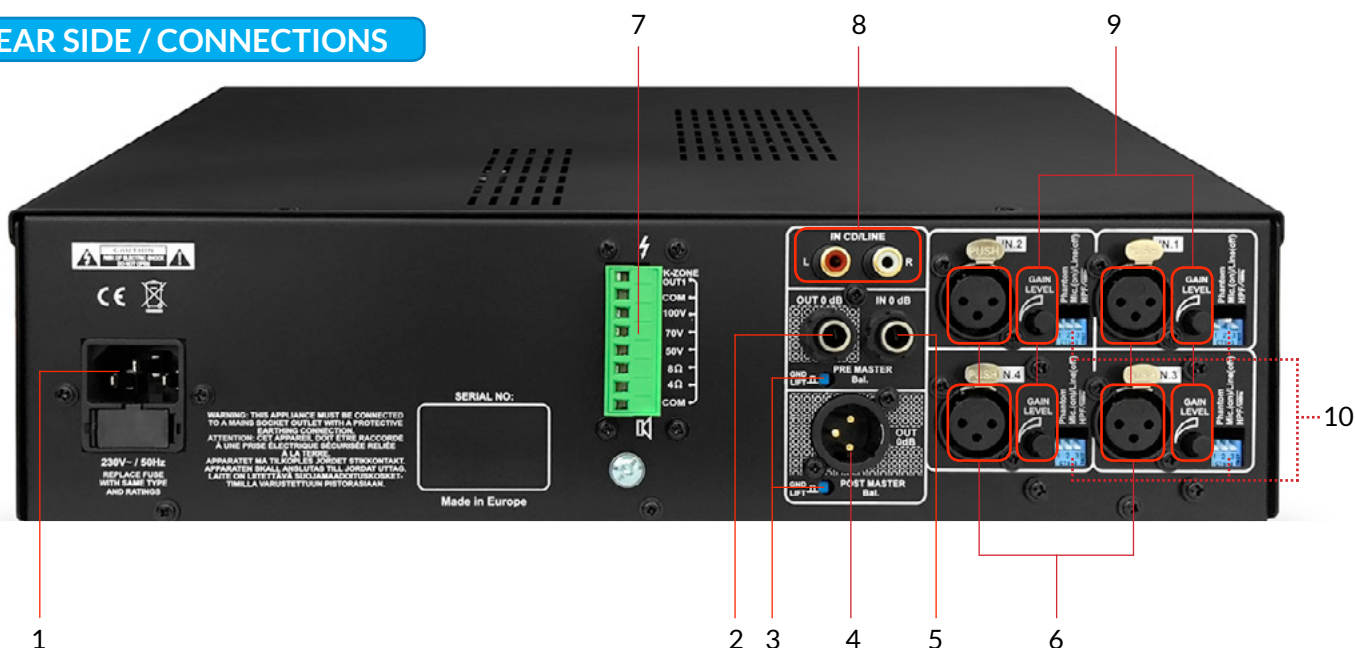

### 1. 230VAC INPUT JACK

IEC socket for connection to 230VAC mains supply with glass fuse.

### 2. LINE OUT (PRE-MASTER)

Balanced output (before EQ and master) LINE 0dB, audio signal expansion output for, e.g. **Audio mixer**, etc.

### 3. GROUND LIFT (SEPARATE PER OUTPUT)

Typical uses in mass ground loops, multi-grounded audio connections, especially when two so-called LINE-LINE devices are coupled together with audio line.

### 4. LINE OUT (POST MASTER)

Balanced linear (after EQ and master) output LINE 0 dB. Audio output for e.g. other power amplifiers: **WM-200DT**, **WM-400DT** and **WM-600DT** or **DIGIVOICE** loudspeaker systems.

### 5. LINE IN (PRE MASTER)

Linear (before EQ and master) balanced input on jack socket (LINE level, +0 dB).

### 6. AUDIO INPUTS 1 to 4

On the rear panel are 4 x XLR audio input sockets. The inputs are balanced +2, -3, 1-shield (see drawing). For each input, the input sensitivity (GAIN) on the rear panel can be adjusted. The channel volume is set on the front panel with separate slide control and 2-point EQ.

### ATTENTION:

All microphone inputs have a switchable phantom power + 24VDC (DIN/IEC standard).

If **unbalanced**, dynamic microphones are connected to the audio inputs, a coupling capacitor must be inserted or the phantom power switched off.

## REAR SIDE / CONNECTIONS

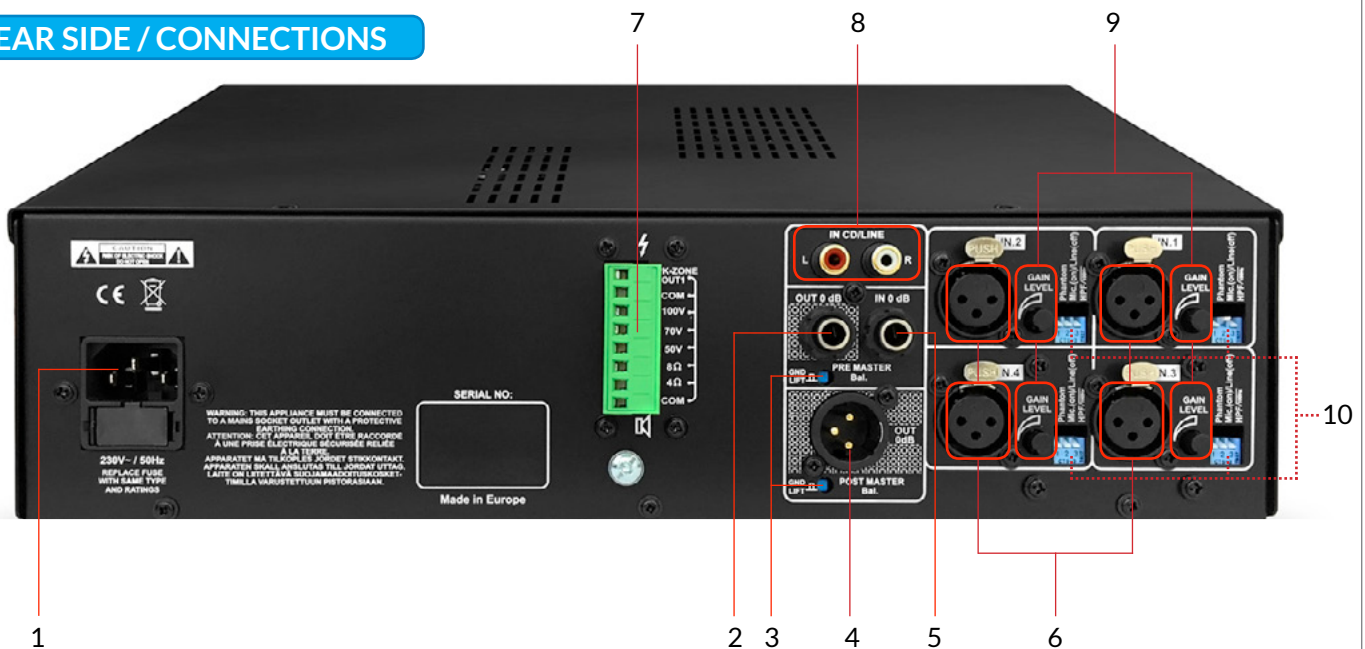

Balanced inputs: Strip the wire conductors by 6 mm and connect them to the terminals as shown. Tighten the screws.

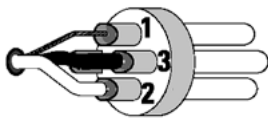

1 GND  
2 +IN  
3 -IN

Unbalanced inputs: Strip the wire conductors by 6 mm and connect them to the terminals as shown. The center pin must be connected to the shielding pin as shown. Tighten the screws.

1 GND und wire bridge to 3  
2 +IN

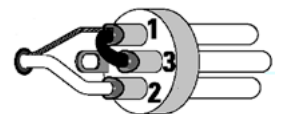

### 7. SPEAKER OUTPUTS

The 100V-speakers are connected to the terminal 100V and COM-Pin.  
Low-impedance loudspeakers with an impedance of 8 or 4 ohms are connected to the 8 ohm terminals or 4 ohms and COM. Fig. 1 shows the speaker output terminal with Zone-OUT-1.

**Attention:**

**Only 100V speakers OR low impedance speakers can be connected - simultaneous use is not possible.**

Speaker output ZONE 1 is supplied from the internal power output stage. The output is 100V with the maximum power of 200 watts.  
**Drawing: YELLOW=100V, BLACK=COM**

A direct loudspeaker output is supplied from the internal power output stage. The output is 100V with the maximum power of 200 watts.  
**Drawing: BLUE=100V, BLACK=COM.**



Please note that the ZONE-1 output and the direct loudspeaker output are supplied from the same power output stage. The connected load at ZONE 1 and the direct output should not exceed more than 200 watts.

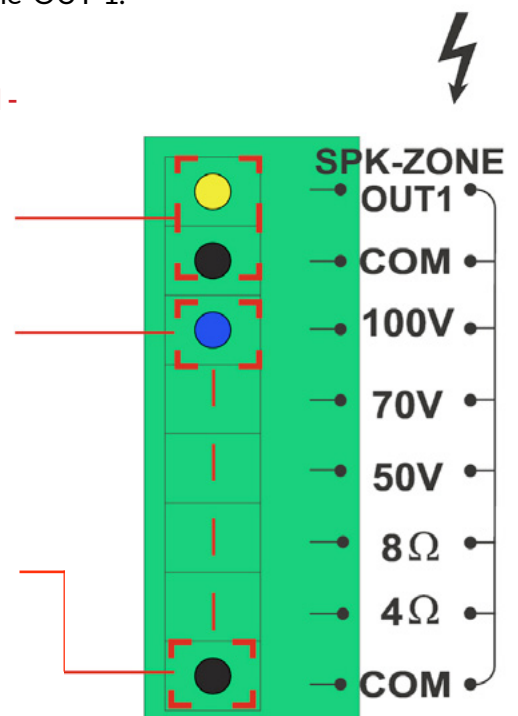

(Fig. 1)

## REAR SIDE / CONNECTIONS

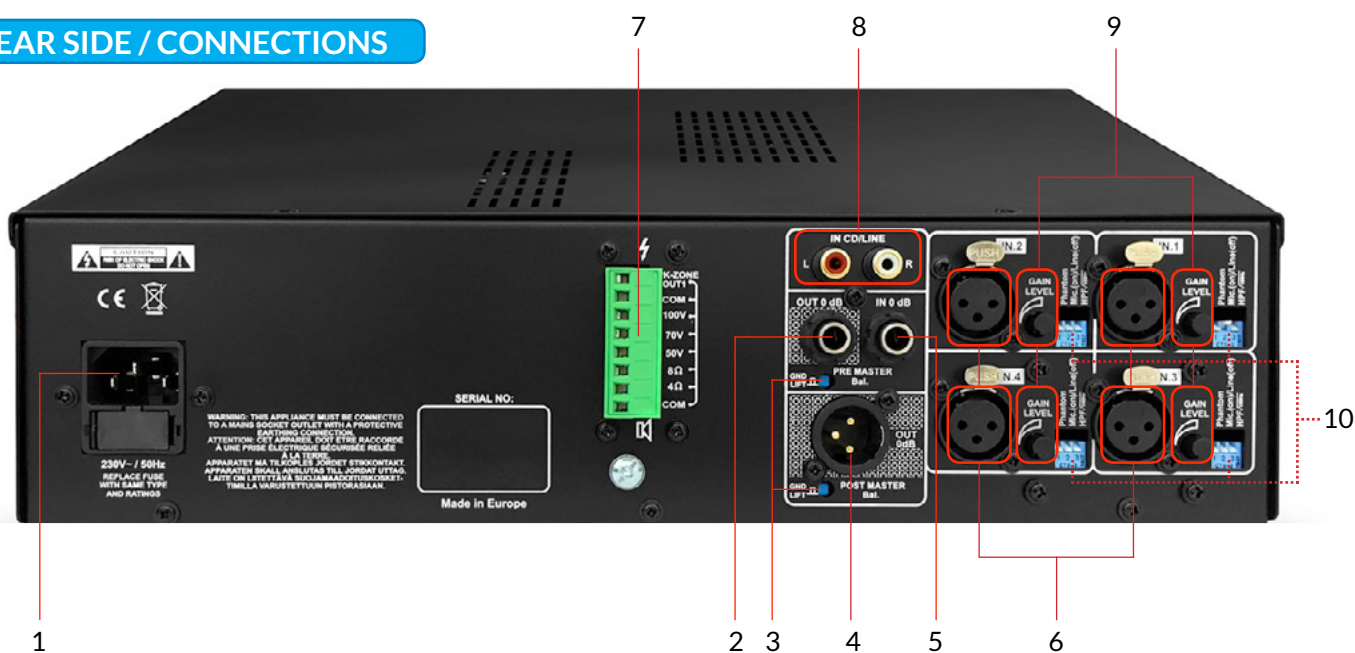

### 8. LINE IN-9

Unbalanced RCA connector (LINE level, +0 dB). The connections are unbalanced and are suitable for stereo sound carriers. L + R are interconnected internally via an OP 1/1. The volume and LF/HF controls are provided on the front with front slider or LF/HF with spindle trimmers.

### 9. GAIN CONTROL

Each input channel has an independent gain control.

DIP switch (position: MIC) ON-position: -40dB / -15dB, DIP switch (position: LINE) OFF position: -15dB / +5dB.

### 10. DIP SWITCH (MIC. LINE / PHANTOM POWER / FILTER HPF 100Hz)

Each input channel has a DIP switch, allowing the following states to be selected:

- DIP-1 (ON)** Input is supplied with 24VDC phantom power for condenser microphones.
- DIP-1 (OFF)** Phantom power is disabled.
- DIP-2 (ON)** Input is set to the microphone input sensitivity.
- DIP-2 (OFF)** Input is set to the LINE input sensitivity.
- DIP-3 (ON)** Input low-cut filter (100Hz) to remove low frequencies is activated.
- DIP-3 (OFF)** The low-cut filter (100Hz) is deactivated.

## EXAMPLE OF AMPLIFIER OPERATION IN THE SOUND SYSTEM (WITH PV-7D.4-2U)

The diagram below shows an example of connection of external devices to the amplifier. This system will vary depending on the application and the client's requirements.

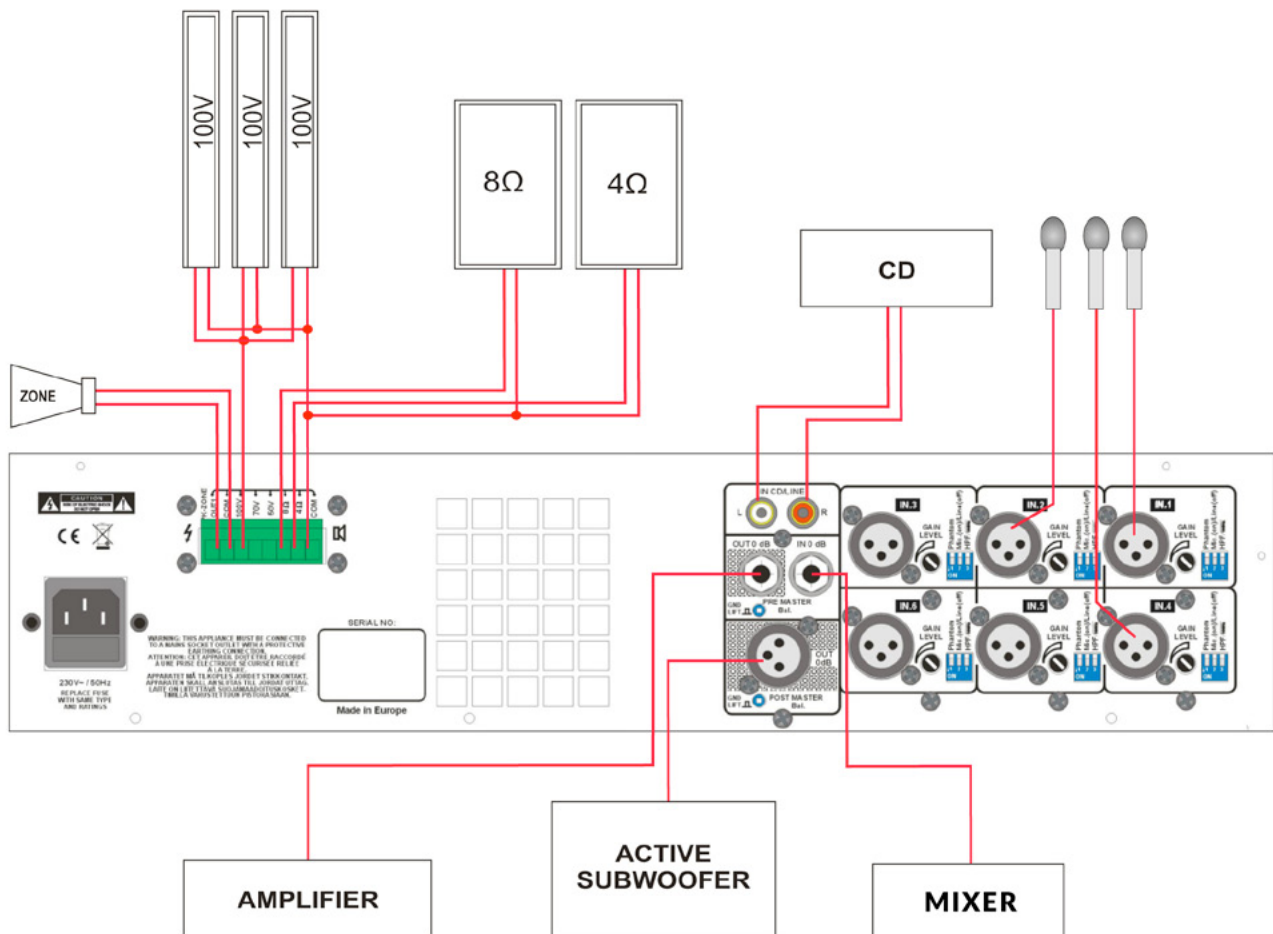

## ROOM EQUALIZATION

Thank you for purchasing the POWERVOICE automatic mixing amplifier from Phoenix Professional Audio. In order to use it correctly and to be able to use all the technical possibilities offered by the POWERVOICE amplifier, you must carry out a spatial adjustment or room equalization after installation. To realize a room measurement, you need a measuring device. The minimum is the NTI Audio® Mini-Analyzer or professional measurement software such as MLSSA.

For a practical measurement the measuring microphone has to be positioned exactly at the place where later the audience will be (f.i. for church acoustics in the middle of the church). By generating „PINK NOISE“ to the POWERVOICE amplifier you measure the amplitude frequency response with the measuring microphone.

If the frequency response determined does not have the desired characteristics, room adjustment filters (EQ) are used for adjustment by increasing or lowering the frequency spectrum in determined areas (see Fig. No.1).

Repeat the measurement and correction process until a linearity arises (see Fig. No.2).

In big halls or in bigger distance from the signal sources (f.i. speakers) a treble reduction occurs. For reverberant rooms it makes sense to concentrate additionally on the equalization of low frequencies up to 100-800 Hz. In this frequency range is the highest reverberation effect.

It has been shown that it is important to be careful with the equalization. The efficiency of the speaker and the amplifier should always be taken into account.

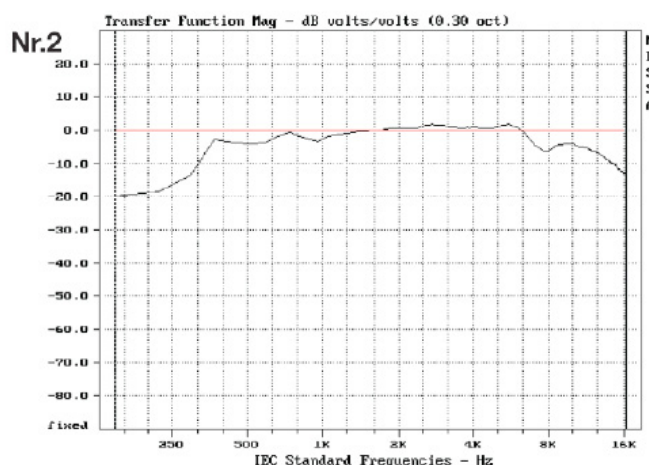
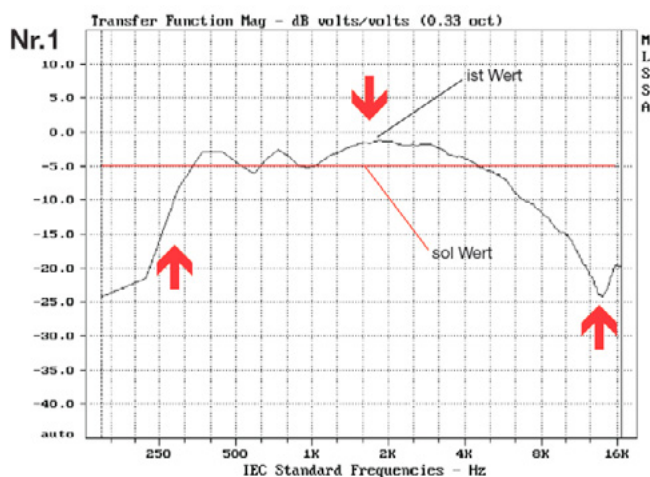

## ROOM EQUALIZATION

### Equalization for positive feedback suppression

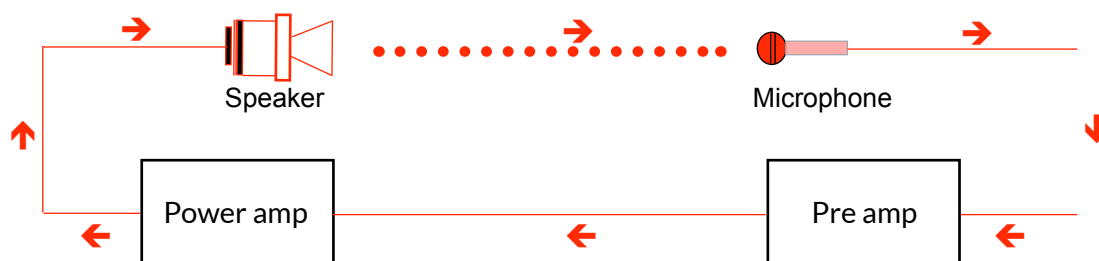

The positive feedback between microphone and loudspeaker generates the so-called feedback, which always starts at the frequency at which the transmission curve has the strongest maximum. This can be attenuated by the **automatic feedback limiter** included in the POWERVOICE amplifier as follows:

First you should reduce the disturbing frequency with the **G-EQ** by a desired value (dB). Then generate feedback again by increasing the microphone sensitivity. Measure the occurring frequency (Hz) and correct it with the next or corresponding G-EQ.

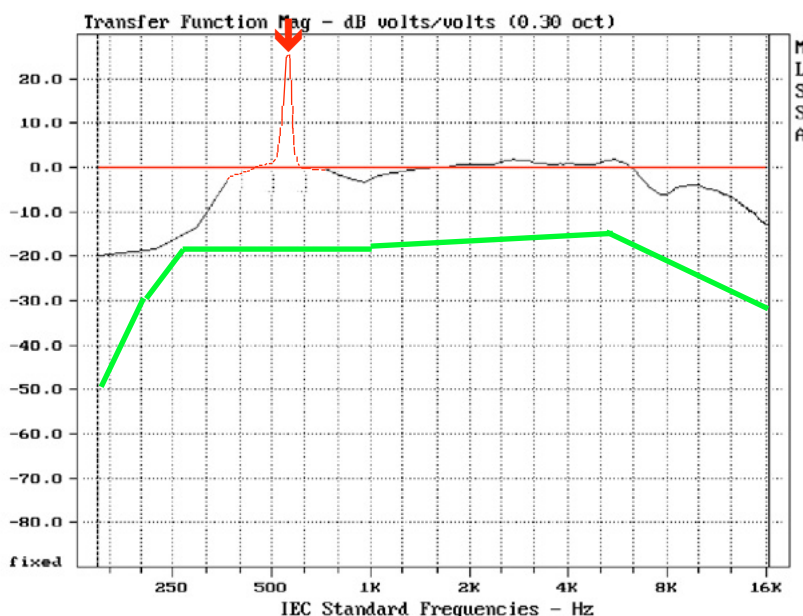

The automatic mixer amplifier **PV-5D.2-2U (POWERVOICE)** series has 21 graphic input EQ.

As a result, acoustically difficult rooms can be better equalized and the microphone sensitivity can be increased without disturbing feedback. After the audio leveling by the frequency compensation, the frequency SHIFTER can now be tuned in for safety.

# PV-5D.2-2U

Instruction manual

## DIMENSION DRAWING

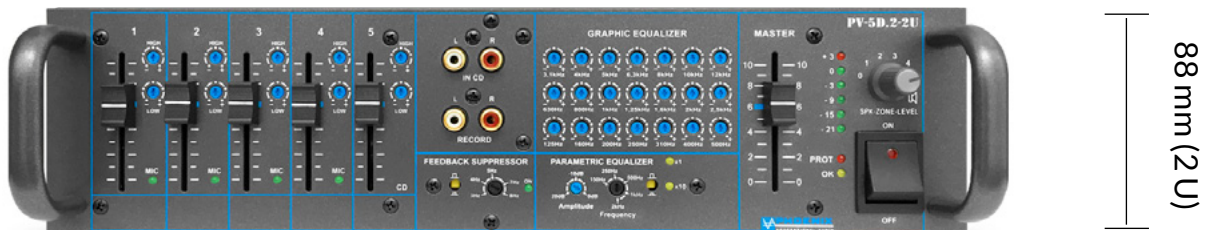
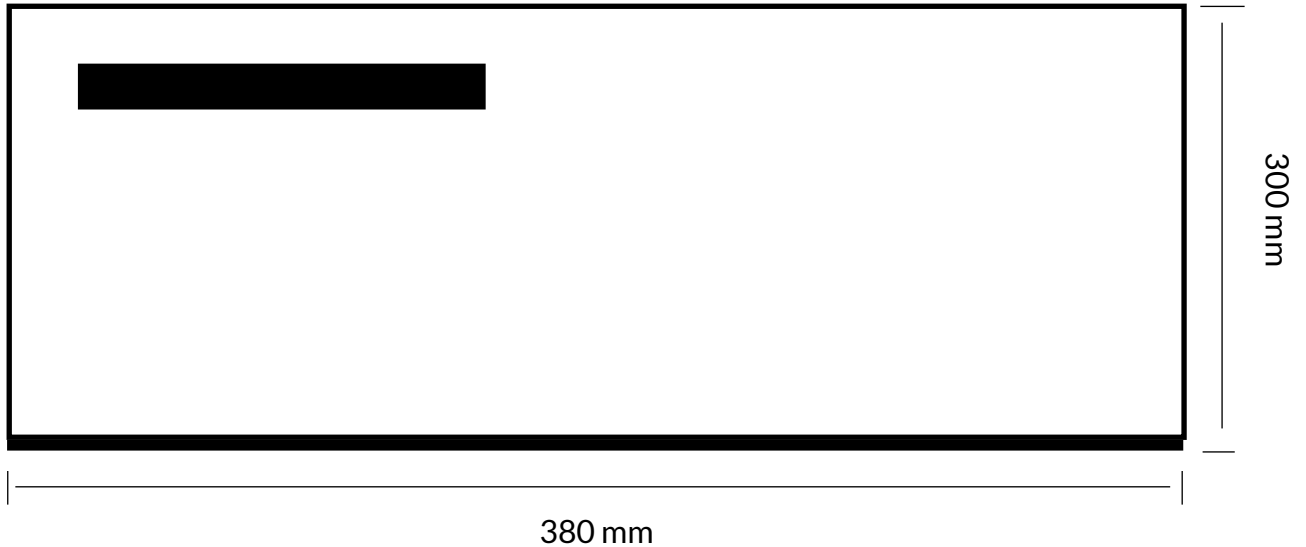

## TECHNICAL DATA

### TECHNICAL DATA

### PV-5D.2-2U

|                                     |   |
|-------------------------------------|---|
| Output power                        | 200 Watt Sinus, Digital Power Amp Class D   |
| Speaker outputs, floating:          | 100 V - 70 V - 50 V - 8 and 4 Ohm   |
| Frequency response:                 | 60 Hz to 20.000 Hz  |
| Signal to Noise Ratio:              | Total closed 97 dB  |
| Distortion factor:                  | < 0,1%  |
| Equalization Graphic-EQ (21- BAND): | (Hz) 125, 160, 200, 250, 310, 400, 500, 630, 800, (kHz) 1, 1.2, 1.6, 2, 2.5, 3.15, 4, 5, 6.3, 8, 10, 12 / (+/- 12 dB) |
| Equalization Parametric-EQ:         | x1 & x10 (0dB-20dB, total band width 150Hz bis 20kHz)   |
| Shifter (BYPASS):                   | yes / Shiftershift 3 Hz to 8 Hz / 20 Hz to 20 kHz   |
| Automatic Mixer:                    | Response threshold of the acoustic switch 30 uV to 0.33 mV adjustable (internal)                                      |
| Microphone/Line                     | Automatic, 1 - 4 balanced MIC (- 40dB / - 15dB), 1.6kΩ, LINE (-15db / + 5db) 10k Ω, balanced, XLR Neutrik             |
| Line Input (CD/LINE):               | Unbalanced -10dB/+12dB @ 10kOhm   |
| Line Input (IN 0dB):                | Balanced, PRE-MASTER, 0dB @ 10kOhm to jack  |
| Line Output (OUT 0dB):              | Balanced, PRE-MASTER, 0dB @ 10kOhm to jack with GND- LIFT   |
| Line Output (OUT 0dB):              | Balanced, POST-MASTER, 0dB @ 10kOhm to jack with GND- LIFT  |
| Input Low-Cut-Filter:               | switchable to each input (channels 1 to 4), DIP-3   |
| Phantom Power:                      | 24 VDC, switchable to each input (channels 1 to 4), DIP-1.  |
| Protection circuits:                | On delay, current limit (short circuit), overtemperature protection, inductive load, limiter                          |
| Sound adjuster inputs and sum:      | 2-Band EQ / LF 100 Hz, HF 10 kHz, (+/- 12 dB)   |
| Dimensions / color:                 | 380mm (B) x 88 mm (H) x 300 mm (T) table housing with 2 U, color graphite   |
| Power supply:                       | 230 V AC, 50 / 60 Hz  |
| Weight:                             | approx. 12 kg   |

#### Disclaimer

The author points out that the representations, explanations, calculations and the same contained in the directive are merely exemplary in nature. They reflect the current state of knowledge and the current legal situation, but make no claim to completeness. In view of the complexity of construction projects, the development of individual solutions relevant to the respective project is indispensable. Any liability for the descriptions, applications, indications and transmissions of the guideline or individual details or parts of it shall be hereby expressly excluded.

#### Important notes

The following applies to all pages of this description:  
 Technical changes and printing errors reserved.  
 The pictures are similar, color deviations reserved.